



# BARD FUSION-TEC™ WALL-MOUNT™ Free Cooling DAC Economizer and Air Conditioner

## Bard High Sensible Cooling Systems

WR36 Series 12.5 EER 2 to 3 Ton

WR58 Series 11.0 EER 3.5 to 5 Ton

The FUSION-TEC™ has been designed specifically to optimize Free Direct Ambient Cooling (DAC) opportunities. By implementing a counterflow design, productive outdoor air for free cooling is brought into the system from the lower portion of the chassis. The heat in the shelter is exhausted out of the top of the chassis which completely eliminates any possibility of recirculating hot exhaust into the cool air entryway. When outdoor air is not productive for free cooling, the FUSION-TEC system has a fully flexible mechanical cooling operation that operates at an IPLV of up to 17.0, and also surpasses the D.O.E.'s future 11.0 EER efficiency requirements.

## Engineered Features

**Dual Capacity:** System fluctuates between three cooling capacities when not operating in free cooling mode. The WR Series High Sensible system operates in part load or full load cooling, based upon need and peak efficiency.

**Counterflow:** Peak performance low side air discharge directs the cooler air used for electronics and equipment cooling at floor level where it is needed. The heat from the shelter is pulled back into the FUSION-TEC from ceiling level to be exhausted to the outside, or integrated into the mechanical cooling system.

**DAC Free Cooling Unit:** All units are designed to optimize any free cooling outdoor air opportunities. The FUSION-TEC features positive seal dampers to eliminate unwanted air migration. Peak operation is constantly monitored and deviations result in an alarm. (Free cooling may be disabled via software when needed.) As a safety design, an air quality switch has been integrated into the system to keep dirt and debris out of the building .

**Logic Board:** System control panels are equipped with PLC Logic Boards that allow multiple unit operation (up to 14 units and 3 zones) with a single controller. Unit connection to the LC6000 controller is accomplished with 2 wire shielded cable daisy chain with drain (ground).

**Advanced Unit Diagnostics:** Whether connected to the TEC-EYE™ diagnostic tool, or just viewed from the shelter control, the system PLC Logic Board is able to display stored alarms and easy to read diagnostic information.

**Orphan Mode:** System is designed to run independently if communication to the LC6000 controller is lost, meaning that cooling can be provided even if the controller or wiring fails.

**Airflow Switch:** All systems feature an airflow differential switch to monitor blower operation. Settings are field adjustable with alarm signal.

**Dirty Filter Switch:** All systems include an airflow differential switch to monitor pressure drop across the unit filter. This will indicate when a filter change is needed. Settings are field adjustable with alarm signal. An indicator light is located on the outside of the FUSION-TEC that illuminates when the filter needs replaced.

**High Pressure Transducer:** A high pressure transducer is used for advanced diagnostic features including an alarm signal when condenser coil cleaning is needed.

**Low Pressure Transducer:** A pressure transducer is used for advanced diagnostic features and indication of refrigerant loss. Combined with other sensors, the FUSION-TEC will constantly display superheat readings.

**High Efficiency Indoor Blower:** Using the latest technology DEC Star® and HEB fan designs, the FUSION-TEC achieves peak CFM airflow rates with the lowest energy usage possible.

**High Efficiency Outdoor Fan Motor:** The FUSION-TEC uses a high efficiency ECM fan system to provide air through the condenser coil. By varying the fan speed, the system is able to provide the airflow needed at high and low outdoor temperature conditions.

**Security Features:** By selecting the BardGuard™ option, electronic security features allow the system to sense coil and copper theft, and features multiple alarm options. An in-shelter disarm button allows authorized personnel to service the system.

**Enhanced Grilles:** The FUSION-TEC counterflow design uses enhanced adjustable louver indoor supply and return grilles for maximized airflow and increased cooling dispersion in the structure.



Counterflow Unit



LC 6000 Controller



Globally Recognized. Industry Respected.



R-410A

\* The AHRI Certified® mark indicates Bard Manufacturing Company participation in the AHRI Certification program. For verification of individual certified products, go to [www.ahrirectory.org](http://www.ahrirectory.org).

# Unit Nomenclature

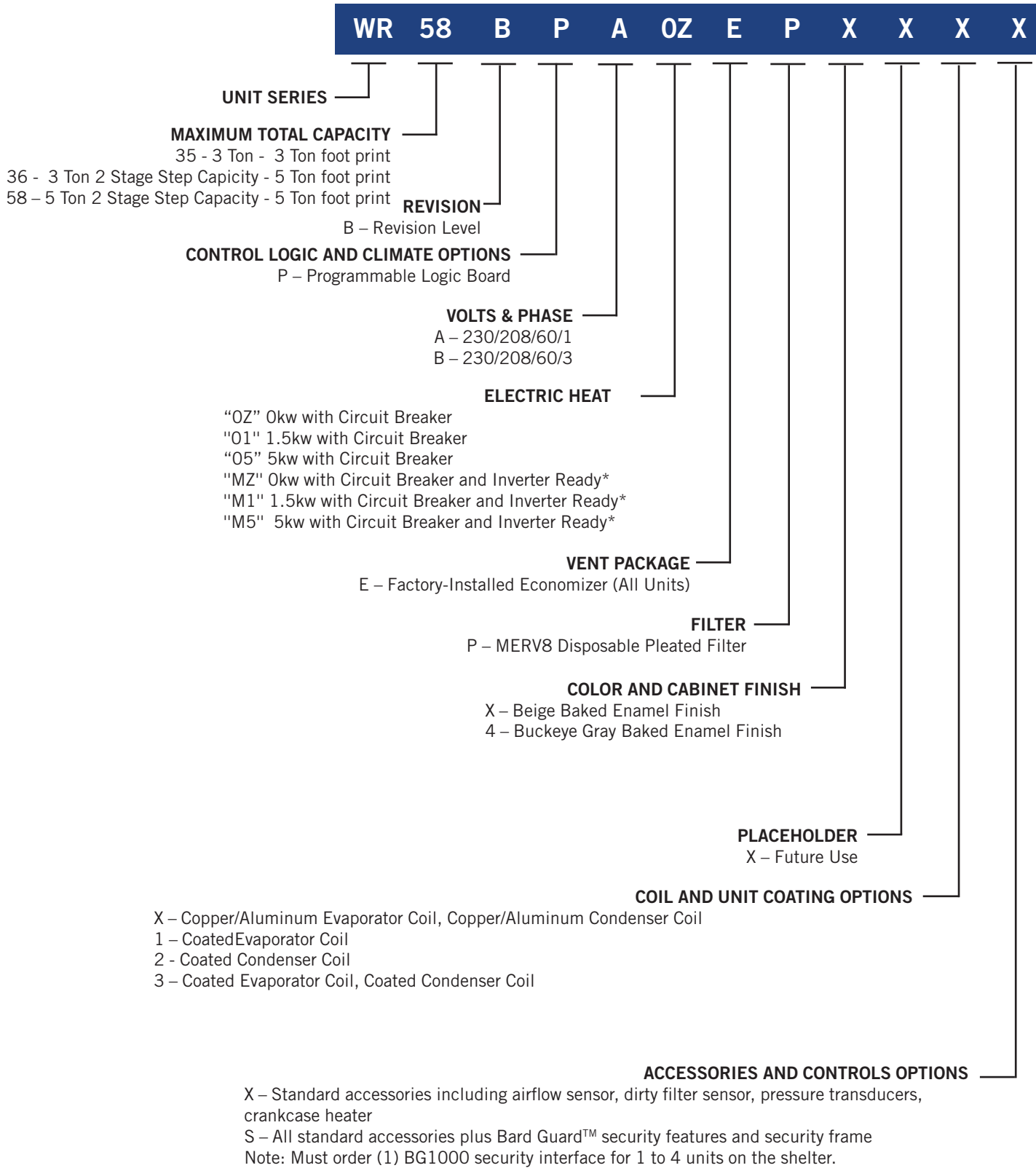

\*Inverter ready heater packages are for use with the VIC1500 inverter. The heater packages will contain a power loss indication relay.

# FUSION-TEC™ WR36 Unit Specifications

Specifications	WR36BPA	WR36BPB
<b>Performance*</b>		
3 Ton Full Load Total Cooling Capacity, BTUH	36,000 BTUH	36,000 BTUH
3 Ton Full Load EER	12.5 EER	12.5 EER
3 Ton Full Load CFM	1200 CFM	1200 CFM
2 Ton Part Load Total Cooling Capacity, BTUH	25,400 BTUH	25,400 BTUH
2 Ton Part Load EER	12.6 EER	12.6 EER
2 Ton Part Load CFM	950 CFM	950 CFM
IPLV (Integrated Part Load Value)	17.0	17.0
SCOP (Sensible Coefficient of Performance)**	3.57	3.57
Rated Voltage	230/208 Volt 1 Phase	230/208 Volt 3 Phase
<b>Compressor</b>		
Operating Voltage Range	197V to 253V	197V to 253V
Rated Load Amps	11.7/13.2	8.7/9.9
Branch Circuit Selection Current Amps	15.6	11.6
Locked Rotor Amps	83	73
Compressor Type	2 Stage Scroll	2 Stage Scroll
Condenser Fan Motor Speeds and Type	Variable ECM	Variable ECM
<b>Condenser Fan and Motor</b>		
Condenser Fan Motor Horsepower	1/3 HP	1/3 HP
Condenser Fan Motor Amps	3.5	3.5
Condenser Fan Motor Min. – Max. RPM	100 – 1200 RPM	100 – 1200 RPM
Condenser Fan Diameter/Rotation	24" CCW	24" CCW
Condenser Fan CFM	2600 CFM Max.	2600 CFM Max.
<b>Blower Motor and Indoor Airflow</b>		
Blower Motor Speeds and Type	Variable ECM	Variable ECM
Blower Motor Horsepower	1/3 HP	1/3 HP
Blower Motor Amps	2.5 A	2.5 A
Blower Motor Max. RPM	1200 RPM	1200 RPM
3 Ton Indoor Blower CFM @ Estimated Static Pressure inch W. C. (Rated, wet coil)	1200 CFM @ 0.0 E.S.P.	1200 CFM @ 0.0 E.S.P.
2 Ton Indoor Blower CFM @ Estimated Static Pressure inch W. C. (Rated, wet coil)	950 CFM @ 0.0 E.S.P.	950 CFM @ 0.0 E.S.P.
Filter Size – Number of filters	20 x 30 x 2 – 2 filters	20 x 30 x 2 – 2 filters

\*Performance data given at AHRI rating conditions.

\*\*SCOP data given at 85°F/64.7°F - 95°F conditions. NEW PART

## WR36 Unit Specifications (continued)

Specifications	WR36BPA	WR36BPB
<b>Refrigeration System</b>		
Refrigeration Flow Control Device	Electronic Expansion Valve	Electronic Expansion Valve
High Pressure Sensor	0-5V Analog Transducer	0-5V Analog Transducer
Low Pressure Sensor	0-5V Analog Transducer	0-5V Analog Transducer
High Pressure Safety Switch	Non-Adjustable NC Switch	Non-Adjustable NC Switch
R410 Refrigerant Charge	102 oz.	102 oz.
<b>Air Pressure and Temperature Sensors</b>		
Dirty Filter Indicator Switch	Adjustable Pressure Switch	Adjustable Pressure Switch
Blower Airflow Indicator Switch	Adjustable Pressure Switch	Adjustable Pressure Switch
Outdoor Air Sensor	10K Analog Sensor	10K Analog Sensor
Return Air Sensor	10K Analog Sensor	10K Analog Sensor
Supply Air Sensor	10K Analog Sensor	10K Analog Sensor
<b>Economizer Specifications</b>		
Damper Motor	24VDC, Modulating (0-10V)	24VDC, Modulating (0-10V)
Damper Blade Switch	Magnetic NO/NC Switch	Magnetic NO/NC Switch
Outdoor Air Quality Sensor	Adjustable Optical Sensor	Adjustable Optical Sensor
<b>Unit Weight Specifications</b>		
Estimated Unit Weight	510 lbs.	510 lbs.
Estimated Unit Shipping Weight	545 lbs.	545 lbs.

# FUSION-TEC™ WR58 Unit Specifications

Specifications	WR58BPA	WR58BPB
<b>Performance*</b>		
5 Ton Full Load Total Cooling Capacity, BTUH	58,000 BTUH	58,000 BTUH
5 Ton Full Load EER	11.0 EER	11.0 EER
5 Ton Full Load CFM	1800 CFM	1800 CFM
3.5 Ton Part Load Total Cooling Capacity, BTUH	42,000 BTUH	42,000 BTUH
3.5 Ton Part Load EER	11.3 EER	11.3 EER
3.5 Ton Part Load CFM	1400 CFM	1400 CFM
IPLV (Integrated Part Load Value)	15.8	15.8
SCOP (Sensible Coefficient of Performance)**	3.23	3.23
Rated Voltage	230/208 Volt 1 Phase	230/208 Volt 3 Phase
<b>Compressor</b>		
Operating Voltage Range	197V to 253V	197V to 253V
Rated Load Amps	20.4/23.0	12.4/14.0
Branch Circuit Selection Current Amps	27.1	16.5
Locked Rotor Amps	152.9	110
Compressor Type	2 Stage Scroll	2 Stage Scroll
Condenser Fan Motor Speeds and Type	Variable ECM	Variable ECM
<b>Condenser Fan and Motor</b>		
Condenser Fan Motor Horsepower	½ HP	½ HP
Condenser Fan Motor Amps	4.3	4.3
Condenser Fan Motor Min. – Max. RPM	100 – 1200 RPM	100 – 1200 RPM
Condenser Fan Diameter/Rotation	24" CCW	24" CCW
Condenser Fan CFM	3300 CFM Max.	3300 CFM Max.
<b>Blower Motor and Indoor Airflow</b>		
Blower Motor Speeds and Type	Variable ECM	Variable ECM
Blower Motor Horsepower	¾ HP	¾ HP
Blower Motor Amps	3.6 A	3.6 A
Blower Motor Max. RPM	1200 RPM	1200 RPM
5 Ton Indoor Blower CFM @ Estimated Static Pressure inch W. C. (Rated, wet coil)	1800 CFM @ 0.0 E.S.P.	1800 CFM @ 0.0 E.S.P.
3.5 Ton Indoor Blower CFM @ Estimated Static Pressure inch W. C. (Rated, wet coil)	1400 CFM @ 0.0 E.S.P.	1400 CFM @ 0.0 E.S.P.
Filter Size – Number of filters	20 x 30 x 2 – 2 filters	20 x 30 x 2 – 2 filters
Filter Rating (Disposable Filter)	MERV8	MERV8

\*Performance data given at AHRI rating conditions.

\*\*SCOP data given at 85°F/64.7°F - 95°F conditions.

## WR58 Unit Specifications (continued)

Specifications	WR58BPA	WR58BPB
<b>Refrigeration System</b>		
Refrigeration Flow Control Device	Electronic Expansion Valve	Electronic Expansion Valve
High Pressure Sensor	0-5V Analog Transducer	0-5V Analog Transducer
Low Pressure Sensor	0-5V Analog Transducer	0-5V Analog Transducer
High Pressure Safety Switch	Non-Adjustable NC Switch	Non-Adjustable NC Switch
R410 Refrigerant Charge	147 oz.	147 oz.
<b>Air Pressure and Temperature Sensors</b>		
Dirty Filter Indicator Switch	Adjustable Pressure Switch	Adjustable Pressure Switch
Blower Airflow Indicator Switch	Adjustable Pressure Switch	Adjustable Pressure Switch
Outdoor Air Sensor	10K Analog Sensor	10K Analog Sensor
Return Air Sensor	10K Analog Sensor	10K Analog Sensor
Supply Air Sensor	10K Analog Sensor	10K Analog Sensor
<b>Economizer Specifications</b>		
Damper Motor	24VDC, Modulating (0-10V)	24VDC, Modulating (0-10V)
Damper Blade Switch	Magnetic NO/NC Switch	Magnetic NO/NC Switch
Outdoor Air Quality Sensor	Adjustable Optical Sensor	Adjustable Optical Sensor
<b>Unit Weight Specifications</b>		
Estimated Unit Weight	547 lbs.	547 lbs.
Estimated Unit Shipping Weight	580 lbs.	580 lbs.

## Product Design Features

### Counterflow WR Series in the Standard Wall Mount Footprint

The FUSION-TEC™ WR series counterflow unit uses the advantages of having a high supply opening to draw warm air from the ceiling level, and discharge cooler air where it is needed the most, at equipment and floor level. This is done using the standard wall mount footprint that has been used for years in the shelter and equipment cooling industry and requires minimal or no wall modifications to replace existing wall mount cooling equipment. This is accomplished by reversing the airflow through the existing wall openings.

### An Energy Saving DAC Economizer with Mechanical Cooling

By design, the Bard FUSION-TEC™ WR Series counterflow unit has a built-in free cooling DAC economizer with separated intake and exhaust air paths. Using separate cold air intake and warm room air exhaust openings dramatically reduces the recirculation effect of room air being discharged from the unit and drawn back into the fresh air intake. This makes economizer operation as efficient as possible and allows for proper intake airflow temperature measurement.

**MECHANICAL COOLING**

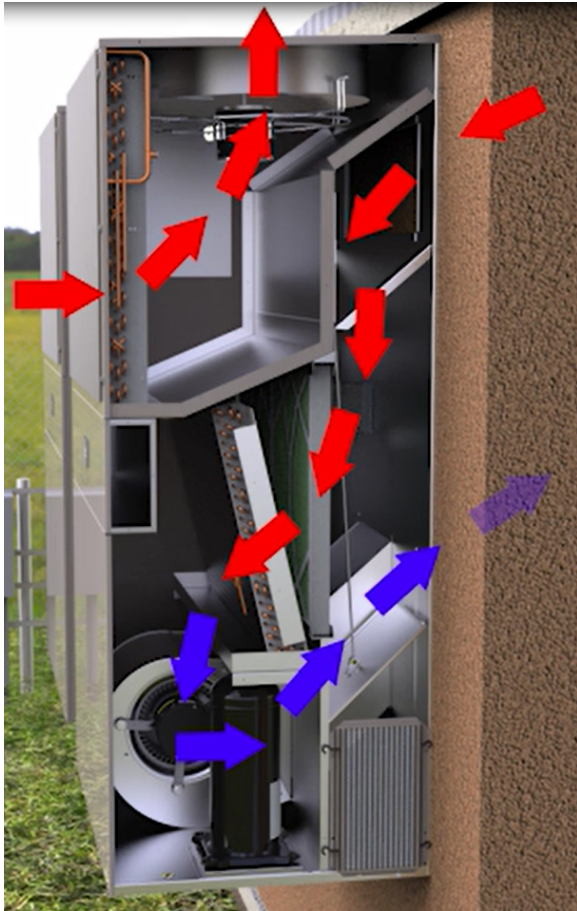

**ECONOMIZER MODE**

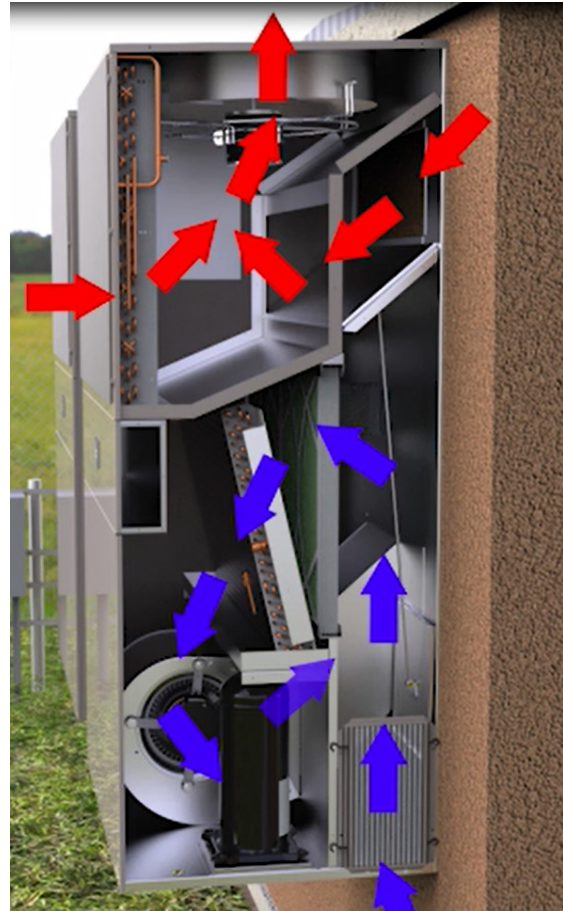



## Unit Options

### Cabinet Finish Options

All unit models are available in Beige and Buckeye Gray. Painted cabinet construction is comprised of 20 guage Zinc coated steel. Parts are cleaned, rinsed, sealed, and dried before a polyurethane primer is applied. The cabinet coating is completed with a baked on textured enamel. The resulting finish is designed to withstand 1000 hours of salt spray tests per ASTM B117-03.



X = BEIGE



4 = BUCKEYE GRAY

### Evaporator and Condenser Coil Coating Options

All models utilize a copper/aluminum evaporator and condenser coil. An additional corrosion resistant AeroMarine coating may be ordered for the evaporator coil, condenser coil or both evaporator and condenser coils.

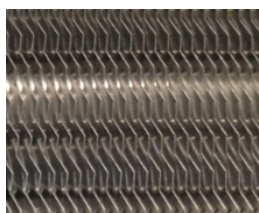

Aluminum Fin  
(standard evaporator)

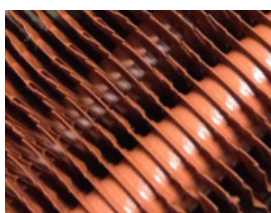

AeroMarine Fin  
(optional coil coating)



## Optional Dip Coated Evaporator and Condenser Coil

Bard now offers TECHNICOAT AA, a robust dipped coating option for the evaporator and condenser coil. TECHNICOAT AA has passed all HVAC accelerated tests like salt spray, flexibility and SWAAT 3,000+ hours. It has been tested in the field in the most severe industrial exposure conditions, such as a coastal refinery in Saudi Arabia, mining facilities in central Africa, and various Pacific islands. TECHNICOAT AA did not show any deterioration after multiple years of function with coils directly exposed to such harsh environmental conditions. The TECHNICOAT AA coating system is based on modified acrylic waterborne binders with high elongation properties. Aluminum pigmentation has been added to establish exceptional heat transfer, chemical resistance, and UV blocking properties. Corrosion resistance reaches >10,000+ hours in ASTM B-117 and >3.120 hours in SWAAT testing. Coating is gray in color.

### TEMPERATURE RESISTANCE:

- Maximum up to 248°F (120°C), 480°F (250°C) peak exposure
- Minimum -40°F (-40°C)

### CHEMICAL RESISTANCE:

- Alkalines including Ammoniac solution, Potassium Hydroxide, Calcium Hydroxide, and Magnesium Hydroxide.
- Alcohols including Isopropanol, Butanol, Amyl Alcohol, Benzyl Alcohol, Diacetone Alcohol, Glycerine, Propanol, and Pentanol
- Aliphatic Hydrocarbons including White Spirit, Shellsol, Bitumen, Isopar G, and Paraffin.
- Amines including Triethanolamine, Aniline Sulphate, Hexamethylenetetraamine, Phenyl diamine, Triethylamine, and Methylamine.
- Inorganic Compounds including Hydrogen Carbonate, Hydrogen Sulfide, Nitrous Acid, Sulphuric Acid, and Selenic Acid.
- Aromatic Hydrocarbons including Xylene, Toluene, Asphalt, Anthracene, Benzapherene, Gumlac, Benzine, and Naphtha.
- Fuels and Oils including Diesel, Fuel Oil, Petrol, Super Petrol, Lubricating Oils, Kerosene, Spheric Oils, LPG, and Mineral Oil.
- Ethers including Enthric Oils, Vegetable Oils, Butane, Acetylene, and Methane.
- Halogenated Hydrocarbons including Amyl Acetate, Propyl Acetate, Ethyl Oxalate, Butyl Acetate, and Butyl Propionate.
- Softeners including Palatinol C, Chloroparaffine 5XX, Dioctylphosphate, Desavin, Mesamol, and Dibutylphosphate.
- Organic Compounds including Benzoic Acid, Lactic Acid, Phenols, Fatty Acids, Malic Acid, and Picric Acid.
- Salts and water solutions including Sodium, Potassium, Calcium, Aluminum, Ammonium, Barium, Copper, Lead, and Lithium.
- Many other agents including Phosphor, Zinc, Glucose Syrup, Sulfur, Urea, Menthol, Antimony, Hydrogen, Rubber, and Shellac.

Contact your local Bard distributor or representative for a list of all chemicals and chemical resistance information.

### SPECIAL PROPERTIES:

- Anti-Odor
- Hydrophilic / Hydrophobic
- Anti-Corrosive

### EXPOSURE CONDITIONS INCLUDE:

Food Processing & Storage, Airports, Office Buildings, Hotels, Schools, Warehouses, Water Treatment, Breweries, Paper Mills, Refineries, Power Plants, Meat Processing Industries, Automotive Industries and other locations near shorelines and salt water.

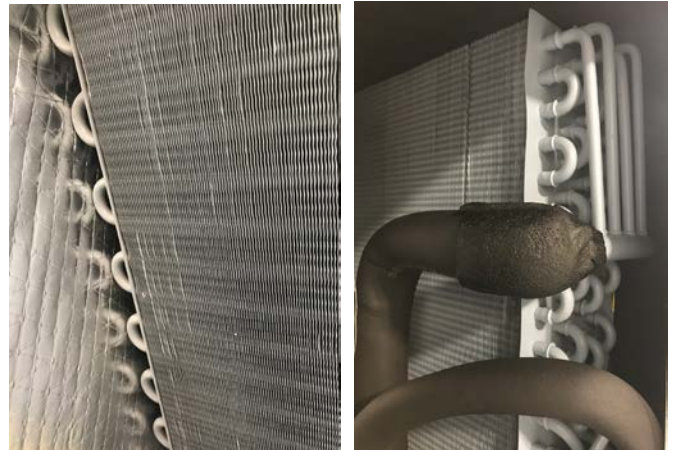

# Control Options

Control Module Code	Field-Installed Part #	Fits Models Listed	Description
X	N/A	All Models	Standard control module package. It contains the following: <ul style="list-style-type: none"> <li>• Logic Control Board</li> <li>• Electronic Expansion Valve</li> <li>• High Pressure Transducer</li> <li>• Low Pressure Transducer</li> <li>• High Pressure Safety Switch</li> <li>• Dirty Filter Pressure Switch</li> <li>• Indoor Blower Operation Switch</li> <li>• Return Air Temperature Sensor</li> <li>• Supply Air Temperature Sensor</li> <li>• Outdoor Temperature and Humidity Sensor</li> <li>• Compressor Control Module</li> <li>• Economizer Intake Air Quality Sensor</li> <li>• Compressor Crankcase Heater</li> <li>• Phase Monitor (3 phase models only)</li> </ul>
S*	N/A	All Models	Security control module package. It contains the standard options listed above and the following: <ul style="list-style-type: none"> <li>• Heavy Duty Security Frame with Easy Service Access</li> <li>• Panel Monitoring Devices</li> <li>• System Pressure Loss Switch</li> <li>• Speaker for Audible Alarm</li> <li>• Indoor Control Box with Arm and Disarm</li> </ul>
N/A	SK-118	208/230-6D-1 60 Units Only	Hard start kit includes the following: <ul style="list-style-type: none"> <li>• Start Relay</li> <li>• Run Capacitor</li> </ul>

\* "S" Control module requires purchase of the BG1000 control box. (1) BG1000 box required per shelter for 1-4 units.

# WR Series Standard Components

## Programmable Logic Board

Each unit uses a programmable logic board located in the unit control panel to communicate with the LC controller. By using a 2-wire connection, alarm functionality and unit operational commands are communicated. If communication is lost, the unit is able to run by using the logic in the unit controller in orphan mode.

## Wall-Mount Unit Control Board

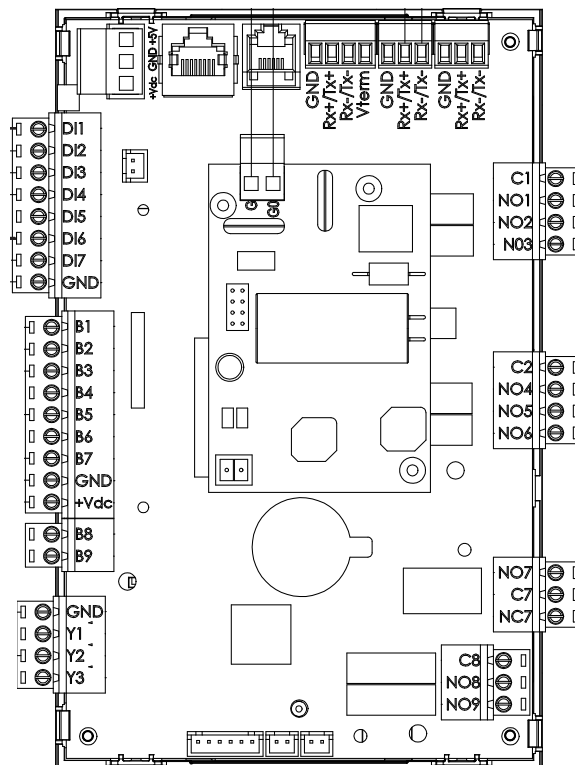

### Power Supply Specifications:

24Vac/Vdc +10%/-15% 50/60 Hz  
Max power input: 28 VA  
Insulation between power supply and instrument:

- Mod. 24Vac: reinforced ensured by the use of external safety (class 2) transformer (mandatory)

External fuse: 3.15 AT (mandatory)  
Minimum section of wires of all other connectors: 0.5mm<sup>2</sup>

### Product Specifications:

Program memory (FLASH): 128MB  
Data memory: 16MB/8MB  
Internal clock precision: 100 ppm  
Battery type: Lithium button battery (removable), BR2032, 3 Vdc  
Battery lifetime characteristics of removable battery; Min. 8 years in normal operating conditions.

### User Interface:

Type: all the pGD terminals with telephone connector J10, th-Tune single unit controller with connector J11/J12/J13

### Operating Conditions:

Storage: -40T70 °C, 90% rH non-condensing  
Operating: -40T60 °C, 90% rH non-condensing

### Other Specifications:

Environmental pollution degree: 3  
Index of protection: IP00  
Class according to protection against electric shock: to be incorporated into Class 1 and/or Class 11 appliances  
PTI of the insulating materials PCB: PTI 250'  
insulation material: PTI 175  
Period of stress across the insulating parts: long  
Type of action: 1C; 1Y for SSR versions  
Type of disconnection or micro interruption: micro interruption  
category of resistance to heat and fire: Category D (UL94 - VO)  
Immunity against voltage surges: Category III  
Rated impulse voltage: 4000V;  
Temperature for Ball Pressure Test: 125 °C

### Communication Lines Available:

- 1 shielded RJ45 Ethernet line. To the Ethernet port only one circuit type SELV CIRCUIT can be connections  
Maximum Ethernet port connection cable length: 100M CAT-5 STP

## WR Series Standard Components

### DEC Star® Indoor Airflow System

DEC Star is the first product to bring together a high efficiency blower (HEB) housing, axial flux (no shaft) BLAC motor, and variable speed ECM technology into one innovative assembly. The DEC Star blower system removes the motor from the blower inlet, eliminating restriction and improving system efficiency.

\*Used on WR58 units only. WR36 units use high efficiency HEB design.

#### Specifications

- High efficiency blower (HEB) housing and impeller driven by axial flux BLAC motor with full featured sinusoidal EON motor control technology
- 10" diameter wheel
- Two patents issued on the unique geometry blower. Other patents pending on the Halo motor system.
- Operating speed range of 250 – 1400 rpm
- 16-pin thermostat and PWM input to control
- Variable speed, constant torque/constant airflow ECM
- 120/240/277 and 120/240 VAC single-phase input, 50/60Hz
- UL and cUL recognized system

### Electronic Expansion Valve (EEV)

The valves are certified in accordance with the main national and international standards. Precise control is guaranteed by electronic controllers, designed especially to optimize management of air conditioning and refrigeration systems, with special focus on energy saving. In addition, highly precise control is also assured by the special shape of the movable elements, guaranteeing flow with an equal percentage characteristic; the stroke length, achieved by using stainless steel ball bearings; and the use of high precision mechanical components.

#### Specifications

- Power supply voltage 12V
- Drive frequency 50 Hz
- Phase resistance (25°C/77°F) 40 Ohm  $\pm$  10%
- Index of protection IP67
- Step angle 7.5 °
- Linear advance/step 0.02 mm (0.001 inches)
- Complete closing steps 500
- Control steps 480



## WR Series Standard Components

### Copeland UltraTech Compressor

The Copeland Scroll UltraTech compressor offers a better means of powering air conditioning systems. Building on established scroll technology, the Copeland Scroll UltraTech compressor provides superior humidity control, greater efficiency and quieter operation, providing unsurpassed reliability and performance along with increased comfort and reduced energy bills.

Modulating compressors provide precise temperature control, lower humidity and greater energy efficiency in comparison to fixed capacity compressors. The Copeland Scroll UltraTech compressor modulates between two capacity settings, 67% and 100%. Two internal bypass ports enable the compressor to run at 67% part-load capacity during times when only part-load cooling is needed. When demand increases, the modulation ring is activated, sealing the bypass ports and instantly shifting capacity to 100%. Running for longer periods at part-load capacity (67%) lowers the humidity inside the building and allows the HVAC system to operate more quietly. With the redesigned Copeland Scroll UltraTech compressor, the VA load is reduced to an expected range of 2-5 VA.



### EC Outdoor Fan Motor

The EC outdoor fan motor maintains its high efficiency across a wide operating range. The result is a significant reduction in energy use when the motor is run at reduced speeds.

#### Specifications

- ECM Technology
- Enclosed motor housing
- Efficiencies up to 80%
- Variable speed, constant torque, brushless DC motor
- Single-phase input, 50/60Hz
- Designed for direct-drive fan applications
- Operating speed range of 200-1800 RPM
- NEMA 48-frame
- cURus recognized component
- Single shaft with integrated control module



### Dirty Filter Switch

All unit models utilize an adjustable dirty filter pressure switch to indicate when the filter needs to be changed. The dirty filter switch measures the pressure difference on both sides of the filter through tubing routed to the blower and vent areas of the unit. When pressure increases to a pre-set measurement in the switch, an alarm signal is sent to the unit programmable logic board, then to the LC6000 controller. The controller energizes a set of normally open contacts. A LED light is also installed on the exterior cabinet surface to indicate a filter change is required.



## WR Series Standard Components

### Filter Replacement Light

A light is provided on the exterior of the unit that illuminates when the unit filter needs to be replaced. The light is located on the front left side of the cabinet. When the alarm signal for a dirty filter is reset through the LC6000 series controller, the light will no longer be illuminated.



### Indoor Blower Operation Pressure Switch

All unit models will utilize an indoor blower operation switch to indicate when blower airflow is not adequate for unit operation due to a failed evaporator blower motor or other mechanical airflow issue. The switch measures the pressure difference on both sides of the blower partition through tubing routed to the blower inlet and outlet areas of the unit. When pressure decreases below a pre-set measurement in the switch, an alarm signal is sent to the unit programmable logic board, then to the LC6000 series controller. The controller energizes a set of normally open contacts.



### Compressor Control Module

A low voltage monitoring device is used to monitor power and indicate a low incoming voltage situation caused by inadequate shore power or generator operation. The monitoring device protects the unit against compressor contactor “chatter” and reverse compressor rotation during these situations.



### Return Air Temperature Sensor

All unit models have a return air temperature sensor installed for operation in “orphan” mode. The return air temperature sensor is also used for indoor temperature averaging with the use of the LC6000 series controller. The return air sensor is located in the upper part of the return opening in such a way that it is exposed to the entering airstream. Information is received by the unit logic control board using a 10K resistance signal. An alarm will be sent to the LC6000 series controller if the return air temperature sensor is disconnected.



### Supply Air Temperature Sensor

All unit models use a supply air temperature sensor. By monitoring the air temperature leaving the supply opening, the unit logic control board is able to monitor the air entering the shelter. Information is received by the unit logic control board using a 10K resistance signal. An alarm will be sent to the LC controller if the supply air temperature sensor is disconnected.





## WR Series Standard Components

### Outdoor Air Temperature and Humidity Sensor

All unit models use an outdoor air temperature and humidity sensor. Using the sensor, the unit logic control board is able to monitor the outdoor air temperature, humidity and dew point. When conditions are acceptable for bringing in cooler outdoor air, the unit logic control board will allow economizer operation. The unit software can be set to operate economizer in Dry Bulb, Humidity %RH or dew point. An alarm will be sent to the LC6000 series controller if the supply air temperature sensor is disconnected.



### Compressor Crankcase Heater

All unit models have a crankcase heater installed as standard. The crankcase heater is a belly band style heater encircling the base section of the compressor housing. When the unit is not in operation, the crankcase heater is a precautionary measure to prevent compressor oil migration, deter oil and refrigeration from mixing and avoid refrigerant condensation.

**Care must be used when servicing the unit to avoid being burned by the belly band attached to the compressor base.** Always disconnect power when servicing this area of the unit.



### Economizer Air Intake Quality Dust Sensor

All unit models include a dust sensor to monitor the outdoor air quality entering the economizer damper area. When conditions are unacceptable due to particulates in the air including farm field debris, highway dust and dirt, or other particulates, the economizer is disabled.

The sensor monitors dust density by using an optical system. The optical portion of the sensor uses a light-emitting diode and light detector. The sensor is shipped pre-set, but may be adjusted for less or more sensitivity.

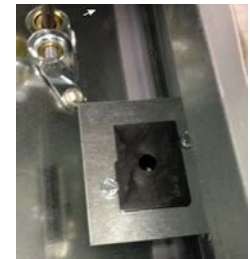

### High Pressure Transducer

All unit models have a high side pressure transducer. The transducer will be used for system monitoring of high side system pressures. This information will be used to indicate when outdoor coil cleaning is necessary based on outdoor conditions and system pressures. When high pressure increases beyond a pre-set measurement when compared to outdoor temperature stored in the unit programmable logic board, an alarm signal is sent from the unit programmable logic board to the LC6000 series controller. The controller energizes a set of normally open contacts to indicate abnormal high system pressure. The high pressure transducer also controls the outdoor condenser fan and motor to increase outdoor airflow during high outdoor ambient conditions. During low outdoor ambient temperatures down to 0°F, the high pressure transducer allows for compressor cooling by cycling the outdoor fan.





## WR Series Standard Components

### Low Pressure Transducer

All unit models have a low side pressure transducer installed on the suction line between the evaporator coil and compressor. The transducer is used for system monitoring of low side system pressures. This information is used to indicate a loss of system refrigerant. When low pressure drops below a pre-set measurement stored in the unit programmable logic board, an alarm signal is sent from the unit programmable logic board to the LC6000 series controller. The controller energizes a set of normally open contacts to indicate abnormal low system pressure. When a loss of charge is measured, the LC6000 series controller energizes a set of normally open contacts to indicate refrigerant loss and that the unit needs to be serviced. The low pressure transducer is also used for operation of the electronic expansion valve (EEV). Superheat is displayed at the unit using the TEC-EYE diagnostic tool.



### High Pressure Safety Switch

All unit models have a high side pressure switch as a safety device. This device is connected to a safety rated set of contacts, and operates if high system pressures reach an unacceptable level. When activated, the unit will shut down compressor operation immediately. After a predetermined time, the unit will attempt to restart. If the switch is activated during the restart, compressor operation will lockout, and an alarm signal will be sent to the LC6000 series controller. **This is a safety device that disables unit operation at a high refrigerant pressure. It is also used to protect unit components including the electronic expansion valve and compressor.** Never disable the high pressure safety switch. Activation of the switch normally indicates the unit needs to be serviced.

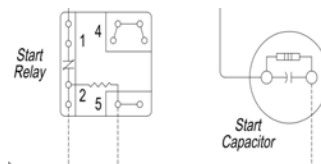

### Field-Installed Hard Start Kit SK-118 (Optional)

All single phase models have a hard start kit available for field installation. The hard start kit may be used to provide additional torque for compressor startup. A relay is provided to energize a start capacitor during the initial starting of the compressor. When the starting winding voltage increases to a set value in the relay, the start capacitor is de-energized.

# WR Series Unit Dimensions – Shelter Top and Side View

## WR36 and WR58 Models

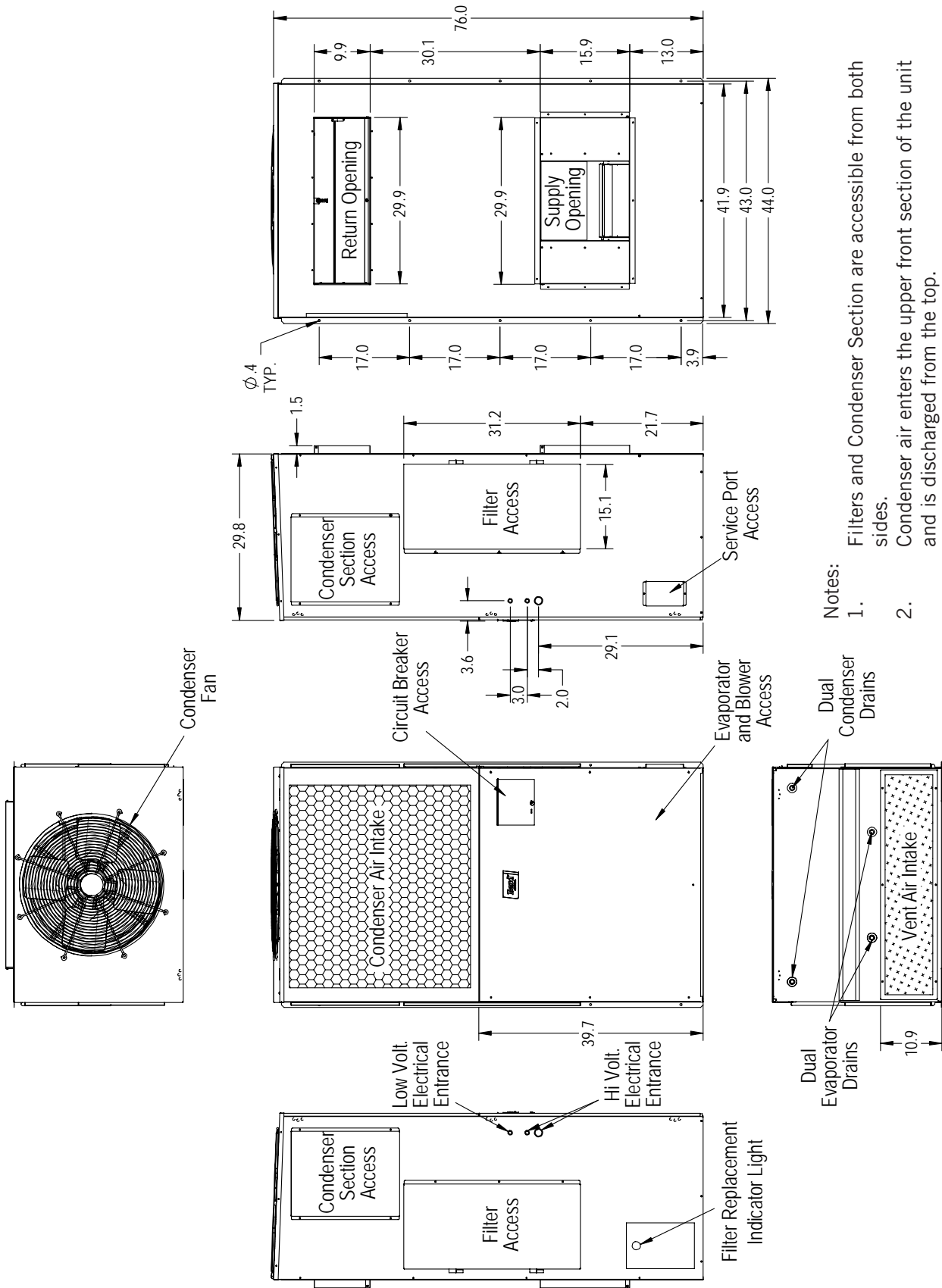

- Notes:
1. Filters and Condenser Section are accessible from both sides.
  2. Condenser air enters the upper front section of the unit and is discharged from the top.
  3. (2) .500" electrical conduit entrances and (1) .750" electrical conduit entrance is provided on each side of the unit.

# WR Series Unit Clearances

Unit	A	C	D	H	W	X	Y	Z
WR36 WR58	24"	15" from snowline	30"	76"	42"	36"	15"	15"

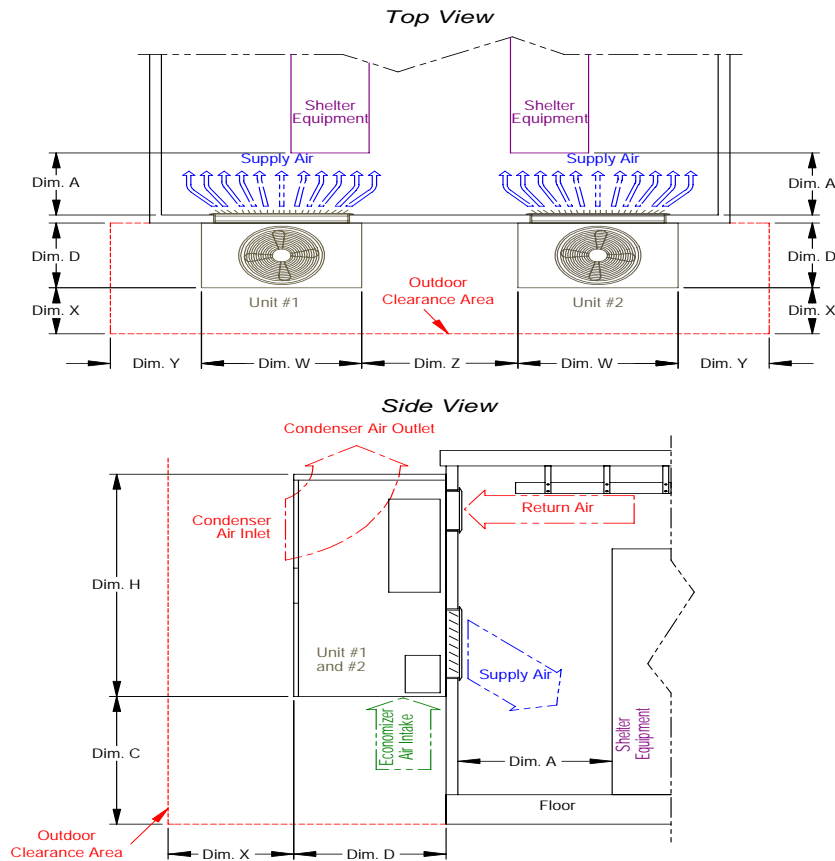

**TABLE 1**  
Clearance Required for Service Access and Adequate Condenser Airflow

Model	Side(s)	Discharge (Top) Overhang 12" or less	Discharge (Top) Overhang Exceeding 12"	Intake (Base)	Front of Unit	Shelter Equipment from Supply Grille
WR36	15"	5"	10"	15" from Snowline	36"	24"
WR58	15"	5"	10"	15" from Snowline	36"	24"

**TABLE 2**  
Minimum Clearances Required to Combustible Materials

Model	Supply Air Flange	Cabinet
WR36	1/4"	0"
WR58	1/4"	0"

## WR36 Mechanical Cooling Performance – 3 Ton Capacity (Full Load)

### Full Load Sensible Capacities

Return Air (DB/WB)	Cooling Capacity	75	80	85	90	95	100	105	110	115	120	125
79/66*	Sensible	32,100	31,600	31,150	30,650	30,200	29,700	29,250	28,750	28,300	27,800	27,350
75/61.1	Sensible	33,450	32,950	32,500	32,000	31,500	30,650	29,850	29,000	28,150	27,350	26,500
80/62.9	Sensible	38,250	37,700	37,150	36,550	36,000	34,600	33,250	31,850	30,500	29,100	27,700
85/64.7	Sensible	41,050	40,100	39,100	38,150	37,150	35,750	34,300	32,900	31,450	30,050	28,600

\*Per NSTD standards for indoor shelter conditions.

## WR36 Mechanical Cooling Performance – 2 Ton Capacity (Part Load)

### Part Load Sensible Capacities

Return Air (DB/WB)	Cooling Capacity	75	80	85	90	95	100	105	110	115	120	125
79/66*	Sensible	27,150	26,550	25,950	25,350	24,700	24,100	23,500	22,900	22,250	21,650	21,050
75/61.1	Sensible	24,650	24,100	23,550	23,000	22,450	21,550	20,700	19,800	18,950	18,050	17,200
80/62.9	Sensible	27,650	27,000	26,400	25,750	25,150	24,050	22,950	21,850	20,750	19,650	18,550
85/64.7	Sensible	29,650	28,850	28,050	27,250	26,400	25,250	24,100	22,950	21,800	20,650	19,500

\*Per NSTD standards for indoor shelter conditions.

## WR36 Free Cooling Economizer Performance

Unit Model	Indoor Airflow	Outdoor Temperature	Indoor Temperature	Free Cooling Sensible Capacity	Free Cooling EER
WR36	1450 cfm	70°F	80°F	15,600 BTUH	52
WR36	1450 cfm	60°F	80°F	31,300 BTUH	104.3
WR36	1450 cfm	55°F	80°F	39,100 BTUH	130.3
WR36	1450 cfm	70°F	85°F	23,500 BTUH	78.3
WR36	1450 cfm	60°F	85°F	39,100 BTUH	130.3
WR36	1450 cfm	55°F	85°F	47,000 BTUH	156.6

## WR58 Mechanical Cooling Performance – 5 Ton Capacity (Full Load)

### Full Load Sensible Capacities

Return Air (DB/WB)	Cooling Capacity	75	80	85	90	95	100	105	110	115	120	125
79/66*	Sensible	46,900	45,700	44,600	43,500	42,500	41,600	40,700	39,900	39,100	38,400	37,700
75/61.1	Sensible	56,200	54,600	53,000	51,400	49,800	48,400	47,000	45,650	44,250	42,850	41,500
80/62.9	Sensible	55,300	53,750	52,150	50,600	49,000	46,250	43,500	40,750	38,000	35,250	32,500
85/64.7	Sensible	61,200	60,150	59,100	58,100	57,000	53,850	50,650	47,450	44,250	41,050	37,850

\*Per NSTD standards for indoor shelter conditions.

## WR58 Mechanical Cooling Performance – 3.5 Ton Capacity (Part Load)

### Part Load Sensible Capacities

Return Air (DB/WB)	Cooling Capacity	75	80	85	90	95	100	105	110	115	120	125
79/66*	Sensible	35,800	34,600	33,500	32,400	31,400	30,500	29,600	28,800	28,000	27,300	26,600
75/61.1	Sensible	42,300	41,000	39,700	38,450	37,200	34,850	32,600	30,250	27,950	25,700	23,350
80/62.9	Sensible	42,050	40,750	39,500	39,200	38,900	35,800	34,700	33,550	32,450	31,300	30,200
85/64.7	Sensible	46,300	45,300	44,300	43,300	42,300	41,000	39,750	38,400	37,150	35,900	34,650

\*Per NSTD standards for indoor shelter conditions.

## WR58 Free Cooling Economizer Performance

Unit Model	Indoor Airflow	Outdoor Temperature	Indoor Temperature	Free Cooling Sensible Capacity	Free Cooling EER
WR58	1950 cfm	70°F	80°F	21,060 BTUH	36.3
WR58	1950 cfm	60°F	80°F	42,120 BTUH	72.7
WR58	1950 cfm	55°F	80°F	52,650 BTUH	90.9
WR58	1950 cfm	70°F	85°F	31,590 BTUH	54.5
WR58	1950 cfm	60°F	85°F	52,650 BTUH	90.9
WR58	1950 cfm	55°F	85°F	63,180 BTUH	109.1

## WR36 Electrical Specifications

Model	Rated Volts & Phase	No. Field Power Circuits	Single Circuit			
			③ Minimum Circuit Ampacity	① Maximum External Fuse or Circuit Breaker	② Field Power Wire Size	② Ground Wire
WR36BPZ, BPMZ BP01, BPM1 BP05, BPM5	230/208-1	1	26	35	8	10
		1	26	35	8	10
		1	30	35	8	10
WR36BP BP0Z BP05	230/208-3	1	25	30	8	10
		1	25	30	8	10

① Maximum size of the time delay fuse or circuit breaker for protection of field wiring conductors.

② Based on 75°C copper wire. All wiring must conform to the National Electrical Code and all local codes.

③ These "Minimum Circuit Ampacity" values are to be used for sizing the field power conductors. Refer to the National Electrical code (latest version), Article 310 for power conductor sizing.

**CAUTION:** When more than one field power circuit is run through one conduit, the conductors must be derated. Pay special attention to Note 8 of Table 310 regarding Ampacity Adjustment Factors when more than three current carrying conductors are in a raceway.

**IMPORTANT:** While this electrical data is presented as a guide, it is important to electrically connect properly sized fuses and conductor wires in accordance with the National Electrical Code and all local codes.

## WR36 Recommended Airflow

Nominal Rated CFM		Nominal Rated ESP
High	Low	
1200	950	.00"wc.

## WR36 Indoor Blower Performance

Speed	High		Low	
	Dry Coil	Wet Coil	Dry Coil	Wet Coil
ESP (Inch H <sub>2</sub> O)				
.00"wc.	1260	1200	995	950

## WR36 Maximum ESP of Operation Electric Heat Only

Model	Static Pressure*
A0Z, AMZ	.00"wc
A01, AM1	.00"wc
A05, AM5	.00"wc
B0Z	.00"wc
B05	.00"wc

\* Unit is rated for free blow non-ducted operation with SGR-5W Supply Grille and RGR-5W Return Grille.

## WR36 Electric Heating Performance

Model	kw	Voltage	Phase	Amps @ 230V/208V	BTUH
A01, AM1	1.5kw	230 volt	1	6.3/5.5	5,120
A05, AM5	5kw	230 Volt	1	20.8/18.1	17,065
B05	5kw	230 Volt	3	14.4/12.5	17,065

## WR58 Electrical Specifications

Model	Rated Volts & Phase	No. Field Power Circuits	Single Circuit			
			③ Minimum Circuit Ampacity	① Maximum External Fuse or Circuit Breaker	② Field Power Wire Size	② Ground Wire
WR58BPOZ, BPMZ	230/208-1	1	43	60	8	10
BP01, BPM1		1	43	60	8	10
BPO5, BPM5		1	43	60	8	10
WR58BPOZ	230/208-3	1	30	45	8	10
BP05		1	30	45	8	10

① Maximum size of the time delay fuse or circuit breaker for protection of field wiring conductors.

② Based on 75°C copper wire. All wiring must conform to the National Electrical Code and all local codes.

③ These "Minimum Circuit Ampacity" values are to be used for sizing the field power conductors. Refer to the National Electrical code (latest version), Article 310 for power conductor sizing.

**CAUTION:** When more than one field power circuit is run through one conduit, the conductors must be derated. Pay special attention to Note 8 of Table 310 regarding Ampacity Adjustment Factors when more than three current carrying conductors are in a raceway.

**IMPORTANT:** While this electrical data is presented as a guide, it is important to electrically connect properly sized fuses and conductor wires in accordance with the National Electrical Code and all local codes.

## WR58 Recommended Airflow

Nominal Rated CFM		Nominal Rated ESP
High	Low	
1800	1400	.00"wc

## WR58 Indoor Blower Performance

Speed	High		Low	
	Dry Coil	Wet Coil	Dry Coil	Wet Coil
.00"wc	1885	1800	1470	1400

## WR58 Maximum ESP of Operation Electric Heat Only

Model	Static Pressure*
A0Z, AMZ	.00"wc
A01, AM1	.00"wc
A05, AM5	.00"wc
B0Z	.00"wc
B05	.00"wc

\* Unit is rated for free blow non-ducted operation with SGR-5W Supply Grille and RGR-5W Return Grille.

## WR58 Electric Heating Performance

Model	kw	Voltage	Phase	Amps @ 230V/208V	BTUH
A01, AM1	1.5kw	230/208 volt	1	6.3/5.5	5,120
A05, AM5	5kw	230/208 Volt	1	20.8/18.1	17,065
B05	5kw	230/208 Volt	3	14.4/12.5	17,065



# WR36 Series Dehumidification Operation

The FUSION-TEC™ WR Series unit is able to operate in a dehumidification mode when the humidity level reaches 80% RH. By running the unit at a lower blower speed, latent capacity is increased and water is removed from the shelter indoor air.

## WR36BP Dehumidification Mode Performance

Indoor			VALUE	OUTDOOR TEMPERATURE											
DB	WB	RH		60	65	70	75	80	85	90	95	100	105	110	115
80	76.4	85%	Latent	22,100	21,650	21,200	20,800	20,350	19,900	19,350	18,800	18,200	17,650	17,050	16,500
			#-H2o/Hr	20.84	20.43	20.02	19.61	19.20	18.80	18.25	17.71	17.17	16.63	16.09	15.55
			Gallons/Hr	2.50	2.45	2.40	2.35	2.30	2.25	2.19	2.12	2.06	1.99	1.93	1.86
80	75.2	80%	Latent	20,550	20,100	19,700	19,300	18,850	18,450	17,850	17,300	16,750	16,200	15,650	15,100
			#-H2o/Hr	19.39	18.98	18.58	18.18	17.78	17.38	16.86	16.34	15.82	15.30	14.77	14.25
			Gallons/Hr	2.33	2.28	2.23	2.18	2.13	2.09	2.02	1.96	1.90	1.83	1.77	1.71
80	73.9	75%	Latent	19,000	18,600	18,200	17,750	17,350	16,950	16,400	15,850	15,350	14,800	14,250	13,750
			#-H2o/Hr	17.93	17.54	17.15	16.75	16.36	15.97	15.47	14.97	14.47	13.96	13.46	12.96
			Gallons/Hr	2.15	2.10	2.06	2.01	1.96	1.92	1.86	1.80	1.74	1.67	1.61	1.55
80	72.5	70%	Latent	17,450	17,050	16,650	16,250	15,850	15,450	14,900	14,400	13,900	13,400	12,900	12,350
			#-H2o/Hr	16.48	16.09	15.71	15.33	14.94	14.56	14.08	13.59	13.11	12.63	12.15	11.67
			Gallons/Hr	1.98	1.93	1.88	1.84	1.79	1.75	1.69	1.63	1.57	1.52	1.46	1.40
80	71.2	65%	Latent	15,900	15,550	15,150	14,750	14,350	13,950	13,450	12,950	12,450	12,000	11,500	11,000
			#-H2o/Hr	15.02	14.65	14.27	13.90	13.52	13.15	12.68	12.22	11.76	11.30	10.84	10.37
			Gallons/Hr	1.80	1.76	1.71	1.67	1.62	1.58	1.52	1.47	1.41	1.36	1.30	1.24
80	69.7	60%	Latent	14,250	13,850	13,500	13,100	12,750	12,350	11,900	11,400	10,950	10,450	10,000	9,500
			#-H2o/Hr	13.44	13.08	12.72	12.37	12.01	11.65	11.21	10.76	10.31	9.87	9.42	8.97
			Gallons/Hr	1.61	1.57	1.53	1.48	1.44	1.40	1.34	1.29	1.24	1.18	1.13	1.08
80	68.3	55%	Latent	12,550	12,200	11,850	11,500	11,150	10,750	10,300	9,850	9,400	8,950	8,500	8,000
			#-H2o/Hr	11.85	11.51	11.18	10.84	10.50	10.16	9.73	9.30	8.87	8.43	8.00	7.57
			Gallons/Hr	1.42	1.38	1.34	1.30	1.26	1.22	1.17	1.12	1.06	1.01	0.96	0.91
80	66.8	50%	Latent	10,900	10,550	10,200	9,850	9,550	9,200	8,750	8,300	7,850	7,400	7,000	6,550
			#-H2o/Hr	10.27	9.95	9.63	9.31	8.99	8.67	8.25	7.84	7.42	7.00	6.59	6.17
			Gallons/Hr	1.23	1.19	1.15	1.12	1.08	1.04	0.99	0.94	0.89	0.84	0.79	0.74
80	65.3	45%	Latent	9,200	8,900	8,550	8,250	7,950	7,600	7,200	6,750	6,350	5,900	5,500	5,050
			#-H2o/Hr	8.69	8.38	8.08	7.78	7.48	7.18	6.77	6.37	5.97	5.57	5.17	4.77
			Gallons/Hr	1.04	1.01	0.97	0.93	0.90	0.86	0.81	0.76	0.72	0.67	0.62	0.57

## WR36BP Dehumidification Mode Performance

Indoor			VALUE	OUTDOOR TEMPERATURE											
DB	WB	RH		60	65	70	75	80	85	90	95	100	105	110	115
75	71.6	85%	Latent	19,000	18,600	18,200	17,800	17,400	17,050	16,500	16,000	15,500	14,950	14,450	13,950
			#-H2o/Hr	17.90	17.54	17.17	16.80	16.43	16.06	15.58	15.09	14.60	14.12	13.63	13.15
			Gallons/Hr	2.15	2.10	2.06	2.01	1.97	1.93	1.87	1.81	1.75	1.69	1.64	1.58
75	70.4	80%	Latent	17,600	17,200	16,800	16,450	16,050	15,650	15,150	14,700	14,200	13,700	13,200	12,700
			#-H2o/Hr	16.60	16.23	15.87	15.51	15.14	14.78	14.31	13.85	13.38	12.91	12.44	11.98
			Gallons/Hr	1.99	1.95	1.90	1.86	1.82	1.77	1.72	1.66	1.60	1.55	1.49	1.44
75	69.2	75%	Latent	16,200	15,850	15,450	15,050	14,700	14,300	13,850	13,350	12,900	12,400	11,950	11,450
			#-H2o/Hr	15.29	14.93	14.57	14.21	13.86	13.50	13.05	12.60	12.15	11.71	11.26	10.81
			Gallons/Hr	1.83	1.79	1.75	1.71	1.66	1.62	1.57	1.51	1.46	1.40	1.35	1.30
75	68	70%	Latent	14,800	14,450	14,050	13,700	13,300	12,950	12,500	12,050	11,600	11,150	10,650	10,200
			#-H2o/Hr	13.98	13.63	13.28	12.92	12.57	12.22	11.79	11.36	10.93	10.50	10.07	9.64
			Gallons/Hr	1.68	1.63	1.59	1.55	1.51	1.47	1.41	1.36	1.31	1.26	1.21	1.16
75	66.7	65%	Latent	13,450	13,050	12,700	12,350	11,950	11,600	11,150	10,700	10,300	9,850	9,400	9,000
			#-H2o/Hr	12.68	12.33	11.98	11.63	11.28	10.93	10.52	10.11	9.70	9.29	8.88	8.47
			Gallons/Hr	1.52	1.48	1.44	1.40	1.35	1.31	1.26	1.21	1.16	1.11	1.07	1.02
75	65.4	60%	Latent	11,900	11,550	11,200	10,850	10,500	10,150	9,750	9,350	8,900	8,500	8,050	7,650
			#-H2o/Hr	11.23	10.90	10.58	10.25	9.92	9.59	9.20	8.80	8.40	8.01	7.61	7.22
			Gallons/Hr	1.35	1.31	1.27	1.23	1.19	1.15	1.10	1.06	1.01	0.96	0.91	0.87
75	64.1	55%	Latent	10,350	10,050	9,700	9,400	9,050	8,750	8,350	7,950	7,550	7,150	6,700	6,300
			#-H2o/Hr	9.79	9.48	9.17	8.86	8.56	8.25	7.87	7.49	7.11	6.72	6.34	5.96
			Gallons/Hr	1.17	1.14	1.10	1.06	1.03	0.99	0.94	0.90	0.85	0.81	0.76	0.72
75	62.7	50%	Latent	8,850	8,550	8,250	7,950	7,650	7,300	6,950	6,550	6,150	5,750	5,400	5,000
			#-H2o/Hr	8.34	8.06	7.77	7.48	7.19	6.91	6.54	6.17	5.81	5.44	5.07	4.71
			Gallons/Hr	1.00	0.97	0.93	0.90	0.86	0.83	0.78	0.74	0.70	0.65	0.61	0.56
75	61.1	45%	Latent	7,300	7,050	6,750	6,450	6,200	5,900	5,550	5,200	4,850	4,450	4,050	3,600
			#-H2o/Hr	6.90	6.63	6.36	6.10	5.83	5.56	5.25	4.91	4.56	4.19	3.80	3.40
			Gallons/Hr	0.83	0.80	0.76	0.73	0.70	0.67	0.63	0.59	0.55	0.50	0.46	0.41

# WR58 Series Dehumidification Operation

The FUSION-TEC™ WR Series unit is able to operate in a dehumidification mode when the humidity level reaches 80% RH. By running the unit at a lower blower speed, latent capacity is increased and water is removed from the shelter indoor air.

## WR58BP Dehumidification Mode Performance

Indoor			VALUE	OUTDOOR TEMPERATURE											
DB	WB	RH		60	65	70	75	80	85	90	95	100	105	110	115
80	76.4	85%	Latent Btuh	39,200	38,200	37,250	36,250	35,300	34,300	33,150	32,000	30,850	29,700	28,550	27,400
			#-H2o/Hr	36.98	36.04	35.14	34.20	33.30	32.36	31.27	30.19	29.10	28.02	26.93	25.85
			Gallons/Hr	4.44	4.32	4.22	4.10	3.99	3.88	3.75	3.62	3.49	3.36	3.23	3.10
80	75.2	80%	Latent Btuh	33,550	33,050	32,600	32,150	31,650	31,200	30,050	28,900	27,750	26,600	25,450	24,300
			#-H2o/Hr	31.65	31.18	30.75	30.33	29.86	29.43	28.35	27.26	26.18	25.09	24.01	22.92
			Gallons/Hr	3.80	3.74	3.69	3.64	3.58	3.53	3.40	3.27	3.14	3.01	2.88	2.75
80	73.9	75%	Latent Btuh	27,900	27,900	27,950	28,000	28,050	28,100	26,950	25,800	24,650	23,500	22,400	21,250
			#-H2o/Hr	26.32	26.32	26.37	26.42	26.46	26.51	25.42	24.34	23.25	22.17	21.13	20.05
			Gallons/Hr	3.16	3.16	3.16	3.17	3.17	3.18	3.05	2.92	2.79	2.66	2.53	2.40
80	72.5	70%	Latent Btuh	22,200	22,750	23,300	23,850	24,400	24,950	23,850	22,700	21,550	20,400	19,300	18,150
			#-H2o/Hr	20.94	21.46	21.98	22.50	23.02	23.54	22.50	21.42	20.33	19.25	18.21	17.12
			Gallons/Hr	2.51	2.57	2.64	2.70	2.76	2.82	2.70	2.57	2.44	2.31	2.18	2.05
80	71.2	65%	Latent Btuh	16,550	17,600	18,650	19,750	20,800	21,850	20,700	19,600	18,450	17,350	16,200	15,050
			#-H2o/Hr	15.61	16.60	17.59	18.63	19.62	20.61	19.53	18.49	17.41	16.37	15.28	14.20
			Gallons/Hr	1.87	1.99	2.11	2.23	2.35	2.47	2.34	2.22	2.09	1.96	1.83	1.70
80	69.7	60%	Latent Btuh	15,000	15,700	16,400	17,100	17,800	18,500	17,500	16,550	15,550	14,550	13,600	12,600
			#-H2o/Hr	14.15	14.81	15.47	16.13	16.79	17.45	16.51	15.61	14.67	13.73	12.83	11.89
			Gallons/Hr	1.70	1.78	1.86	1.93	2.01	2.09	1.98	1.87	1.76	1.65	1.54	1.43
80	68.3	55%	Latent Btuh	13,500	13,800	14,150	14,500	14,800	15,150	14,300	13,500	12,650	11,800	11,000	10,150
			#-H2o/Hr	12.74	13.02	13.35	13.68	13.96	14.29	13.49	12.74	11.93	11.13	10.38	9.58
			Gallons/Hr	1.53	1.56	1.60	1.64	1.67	1.71	1.62	1.53	1.43	1.34	1.24	1.15
80	66.8	50%	Latent Btuh	11,950	11,900	11,900	11,850	11,850	11,800	11,100	10,450	9,750	9,050	8,350	7,700
			#-H2o/Hr	11.27	11.23	11.23	11.18	11.18	11.13	10.47	9.86	9.20	8.54	7.88	7.26
			Gallons/Hr	1.35	1.35	1.35	1.34	1.34	1.34	1.26	1.18	1.10	1.02	0.94	0.87
80	65.3	45%	Latent Btuh	10,400	10,000	9,600	9,250	8,850	8,450	7,900	7,350	6,800	6,300	5,750	5,200
			#-H2o/Hr	9.81	9.43	9.06	8.73	8.35	7.97	7.45	6.93	6.42	5.94	5.42	4.91
			Gallons/Hr	1.18	1.13	1.09	1.05	1.00	0.96	0.89	0.83	0.77	0.71	0.65	0.59

## WR58BP Dehumidification Mode Performance

Indoor			VALUE	OUTDOOR TEMPERATURE											
DB	WB	RH		60	65	70	75	80	85	90	95	100	105	110	115
75	71.6	85%	Latent Btuh	36,150	34,950	33,800	32,600	31,450	30,250	29,150	28,050	26,950	25,850	24,750	23,650
			#-H2o/Hr	34.10	32.97	31.89	30.75	29.67	28.54	27.50	26.46	25.42	24.39	23.35	22.31
			Gallons/Hr	4.09	3.95	3.82	3.69	3.56	3.42	3.30	3.17	3.05	2.93	2.80	2.68
75	70.4	80%	Latent Btuh	32,550	31,450	30,350	29,300	28,200	27,100	26,050	25,000	23,950	22,950	21,900	20,850
			#-H2o/Hr	30.71	29.67	28.63	27.64	26.60	25.57	24.58	23.58	22.59	21.65	20.66	19.67
			Gallons/Hr	3.68	3.56	3.43	3.32	3.19	3.07	2.95	2.83	2.71	2.60	2.48	2.36
75	69.2	75%	Latent Btuh	25,350	24,450	23,550	22,600	21,700	20,800	19,850	18,950	18,000	17,100	16,150	15,250
			#-H2o/Hr	23.92	23.07	22.22	21.32	20.47	19.62	18.73	17.88	16.98	16.13	15.24	14.39
			Gallons/Hr	2.87	2.77	2.66	2.56	2.46	2.35	2.25	2.14	2.04	1.93	1.83	1.73
75	68	70%	Latent Btuh	21,750	20,950	20,100	19,300	18,450	17,650	16,800	15,900	15,050	14,150	13,300	12,450
			#-H2o/Hr	20.52	19.76	18.96	18.21	17.41	16.65	15.85	15.00	14.20	13.35	12.55	11.75
			Gallons/Hr	2.46	2.37	2.27	2.18	2.09	2.00	1.90	1.80	1.70	1.60	1.50	1.41
75	66.7	65%	Latent Btuh	18,250	17,550	16,850	16,150	15,450	14,750	13,900	13,100	12,250	11,450	10,650	9,800
			#-H2o/Hr	17.22	16.56	15.90	15.24	14.58	13.92	13.11	12.36	11.56	10.80	10.05	9.25
			Gallons/Hr	2.07	1.99	1.91	1.83	1.75	1.67	1.57	1.48	1.39	1.30	1.21	1.11
75	65.4	60%	Latent Btuh	14,800	14,200	13,600	13,000	12,400	11,800	11,050	10,250	9,500	8,750	8,000	7,200
			#-H2o/Hr	13.96	13.40	12.83	12.26	11.70	11.13	10.42	9.67	8.96	8.25	7.55	6.79
			Gallons/Hr	1.67	1.61	1.54	1.47	1.40	1.34	1.25	1.16	1.07	0.99	0.91	0.81
75	64.1	55%	Latent Btuh	11,300	10,800	10,300	9,850	9,350	8,900	8,150	7,450	6,750	6,050	5,300	4,600
			#-H2o/Hr	10.66	10.19	9.72	9.29	8.82	8.40	7.69	7.03	6.37	5.71	5.00	4.34
			Gallons/Hr	1.28	1.22	1.17	1.11	1.06	1.01	0.92	0.84	0.76	0.68	0.60	0.52
75	62.7	50%	Latent Btuh	7,800	7,450	7,050	6,700	6,300	5,950	5,300	4,650	3,950	3,300	2,650	2,000
			#-H2o/Hr	7.36	7.03	6.65	6.32	5.94	5.61	5.00	4.39	3.73	3.11	2.50	1.89
			Gallons/Hr	0.88	0.84	0.80	0.76	0.71	0.67	0.60	0.53	0.45	0.37	0.30	0.23

## FUSION-TEC™ Unit Controllers

Controller	Voltage	Shipping Weight	# of Units	Wall-Mount Units	Remote Communication
LC6000	230VAC	23 lbs	1 to 14 Units	FUSION-TEC™	HTTP/IPV4/Modbus

### LC6000 Series Multi-Unit Controller

The LC6000 Series unit controllers are designed to communicate with one to fourteen FUSION-TEC™ wall mount units. Using a programmable logic board, the LC controller is able to operate all units in a lead/lag configuration for equal unit run time. Normally open or normally closed dry contact points are available for unit and shelter alarming capability. A -48VDC power supply is used to ensure controller is operational during a loss of shore power.



### VIC1500 Inverter

The VIC1500 inverter allows for operation of the FUSION-TEC™ units in free cooling economizer mode during a power outage when a generator is not present at an equipment site. When 230VAC shore power is lost, a power loss relay is activated, and the units will operate in free cooling economizer mode using -24VDC or -48VDC battery power until shore power is restored.

Note: The WR series units use the LC6000 controller. The VIC1500 will operate the WR series units when shore power is lost, but will not indicate a fault signal to the controller.

## FUSION-TEC™ Accessories Supplied with LC6000 Controller

Part Number	Description	Quantity Supplied
8301-055	EMI Ferrite Filters	2
8403-079	Remote Indoor Temperature and Humidity Sensor	1
8301-059	TEC-EYE™ Service Tool with 5 ft. Communication Cable	1

### EMI Ferrite Filters Part #8301-055

EMI (electromagnetic interference) ferrite filters are used to keep the communication wiring connecting the FUSION-TEC™ units and the LC6000 series controller from acting as an antenna. As an antenna, the wire could receive electromagnetic interference from other electronic devices in the area.

EMI ferrite filters are attached by forming a wire loop through the filter before connecting each unit. A typical two or four unit installation requires two filters (supplied with LC6000 series controller).



# FUSION-TEC™ Accessories Supplied with LC6000 Controller

## Remote Indoor Temperature and Humidity Sensor Part #8403-079

The remote indoor temperature and humidity sensor is used to measure conditions inside the building. Connected with 18 gauge 5 wire shielded cable, the indoor sensor is able to communicate with the LC6000 series controller and decide when conditions warrant unit operation. Only one (1) temperature and humidity sensor is used for each LC6000 series controller. Up to three (3) optional temperature or temperature/humidity sensors may be used (sold separately) for temperature averaging.



### Technical Specifications:

Storage Temperature: -20°C to 70°C

Temperature Sensor Range: -20°C to 70°C

Humidity Output Signal Range: 0%RH to 100%RH

Temperature Sensor Type: NTC 10K OHM at 25°C 1%

Humidity Sensor Type: Capacitive

Terminal Block Type: Screw terminals for cables, max. dia. 1.5mm min. Ø .5mm

Maximum Wire Length: 1640 Ft. (500m)

Temperature Time Constant: In still air, 300s

Humidity Time Constant: In still air, 60s. In moving air, 20s.

Category of Resistance to Heat and Fire: Category D (for case and cover)

Category of Immunity Against Voltage Surges: Category 2

Sensor Index of Protection: IP30

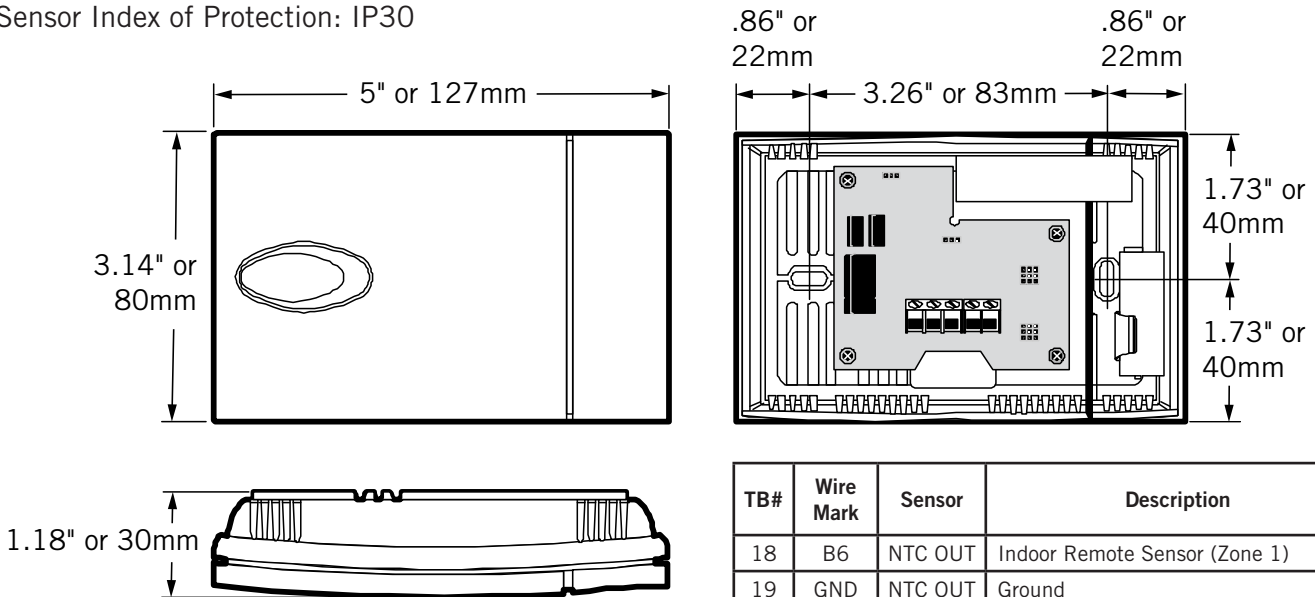

TB#	Wire Mark	Sensor	Description
18	B6	NTC OUT	Indoor Remote Sensor (Zone 1)
19	GND	NTC OUT	Ground
12	B2	OUT H	Remote Indoor Humidity Sensor: 0-1 VDC (Zone 1)
13	GND	M (GO)	Ground
22	+VDC	+ (G)	Power for B2

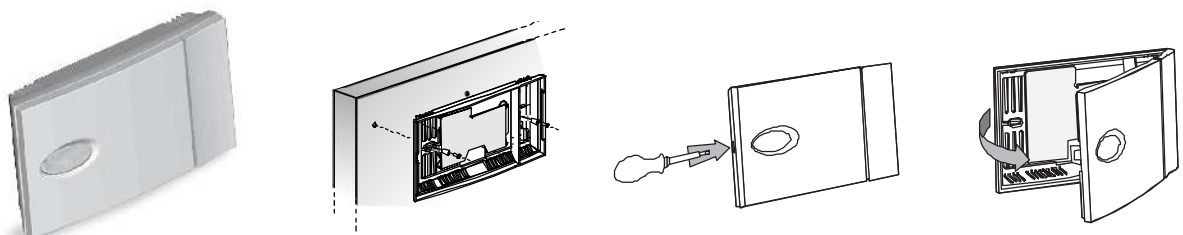

## TEC-EYE™ Service Tool Part #8301-059

The TEC-EYE™ service tool is used to communicate with the FUSION-TEC™ unit logic board. By connecting directly to the logic board inside the unit control panel, it is possible to perform diagnostics on the unit, adjust certain settings and verify unit and economizer operation through a run test procedure. **The TEC-EYE™ service tool is required for unit setup and operation, and is supplied with the LC6000 controller.**



### Technical Specifications:

Storage Temperature: -20°C to 70°C

Operating Conditions: -20°C to 60°C

Display Type: FSTN graphic

Display Backlighting: LED

Graphic Resolution: 132 x 64 pixels

Size of Display Area: 72mm x 36mm

Connector: RJ12 (phone connector)

Maximum Wire Length: 50m, 164 ft.

Category of Resistance to Heat and Fire: Category D and B

Category of Immunity Against Voltage Surges: Category 2

Index of Protection: IP65, UL Type 1

### TEC-EYE™ Display



## FUSION-TEC™ Accessories Supplied with the Unit

### Top Rain Flashing

Top rain flashing is supplied with each FUSION-TEC unit and must be used to avoid water intrusion between the wall and unit top. Follow all instructions for attaching and sealing the top rain angle provided in the FUSION-TEC installation instructions. The top rain flashing is shipped attached to the back of the unit.

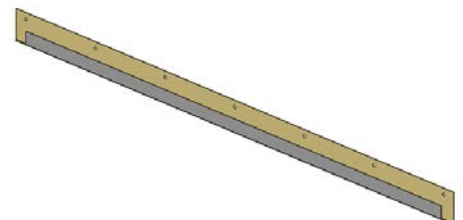

## FUSION-TEC™ Optional Accessories (Sold Separately)

Part Number	Description	Quantity Supplied
8301-058	Additional Remote Indoor Temperature Sensor (18 gauge 2 wire shielded cable sold separately)	1
8403-079	Additional Temperature and Humidity Sensor (18 gauge 5 wire shielded cable sold separately)	1
8301-055	Additional EMI Ferrite Filters	2
8301-053	Large Backlit Display Service Tool	1
2151-021	EEV Manual Adjustment Tool	1
113-140	Bottom Wall Mounting Bracket	1
2151-022	Tri-Groove Socket (Bard Gaurd™ models only)	1

### Remote Indoor Temperature Sensor Part #8301-058

Up to one (1) additional remote temperature sensor in zone 1, and two (2) additional temperature and humidity sensors in zones 2 and 3 may be connected to the LC6000 controller. Connected with 18 gauge 2 wire shielded cable, the indoor temperature sensor is able to communicate with the LC controller and decide when conditions warrant unit operation.

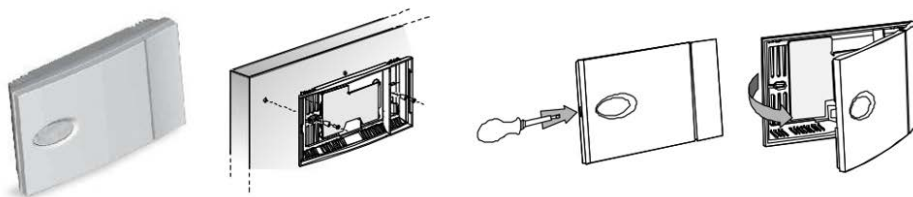
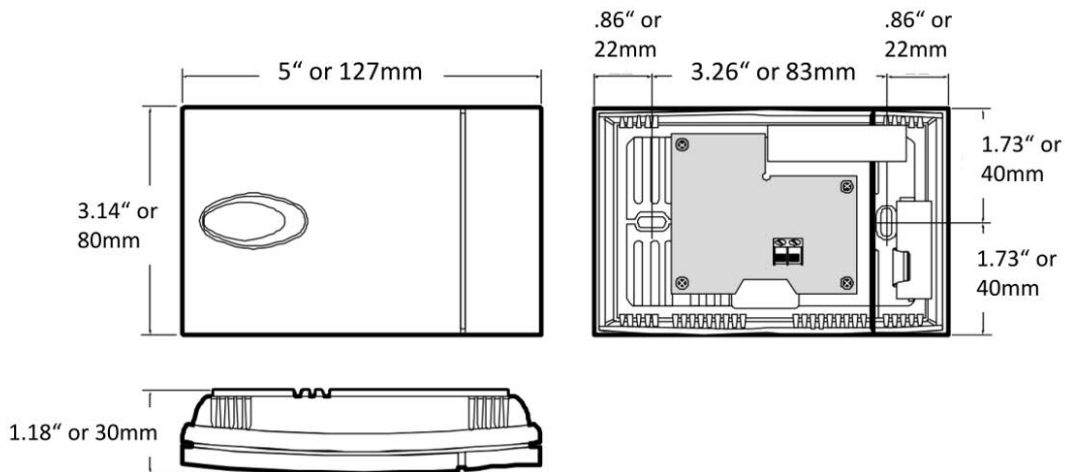



## Large Display Service Tool Part #8301-053

The large display service tool is used to communicate with the FUSION-TEC™ unit logic board. Operation is identical to the TEC-EYE™, with a larger display and mechanical entry keys. By connecting directly to the logic board inside the unit control panel, it is possible to perform diagnostics on the unit, adjust certain settings and verify unit and economizer operation through a run test procedure.



### Technical Specifications:

Storage Temperature: -4°F to 158°F (-20°C to 70°C)  
Operating Conditions: -4°F to 140°F (-20°C to 60°C)  
Display Type: FSTN graphic  
Display Backlighting: LED  
Graphic Resolution: 132 x 64 pixels  
Size of Display Area: 2.8" x 1.4" (72mm x 36mm)  
Connector: RJ12 (phone connector)  
Maximum Wire Length: 50m, 164 ft.  
Category of Resistance to Heat and Fire: Category D and B  
Category of Immunity Against Voltage Surges: Category 2  
Index of Protection: IP65, UL Type 1



## EEV Manual Adjustment Service Tool Part #2151-021

The EEV manual adjustment tool allows for adjustment of the EEV (Electronic Expansion Valve) without the use of the unit logic board. The service technician can use this tool by removing the electronic head of the valve and attaching the adjustment tool. The tool houses magnets that interact with the valve to open or close the EEV for charging or evacuating the system without system power.



## Bottom Mounting Bracket Part #113-140

A bottom mounting bracket may be used to help support the unit during and after installation. The front lip of the bracket hooks underneath the unit base. This part is not supplied with the FUSION-TEC unit, but is available as an optioned accessory.

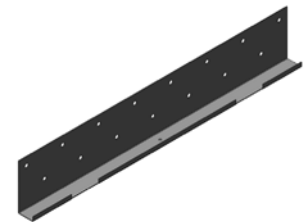

## FUSION-TEC™ Airflow Accessories (Sold Separately)

Part Number	Description	Shipping Weight	Quantity Supplied
SGR-5W	Supply Grille, 2" Wide Frame	6 pounds	1
RGR-5W	Return Grille, 2" Wide Frame	12 pounds	1
8620-286	Condenser pre-filter kit for WR36 and WR58 units	5 pounds	1

### 16" x 30" Supply Grille, Wide Frame Part #SGR-5W

The FUSION-TEC™ unit requires a specially designed supply grille that allows for high velocity airflow through the unit supply opening. The grille finish is powder coated white. Wide frame grilles are used where wall hole sizes require a 2" wide grille flange to cover the wall opening. Used with WR36 and WR58 models.



### 10" x 30" Return Grille, Wide Frame Part #RGR-5W

The FUSION-TEC™ unit requires a specially designed return grille that allows for high velocity airflow through the unit return opening. Deflectors allow for air distribution at floor level, and are adjustable. The grille finish is powder coated white. Wide frame grilles are used where wall hole sizes require a 2" wide grille flange to cover the wall opening. Used with WR36 and WR58 models.

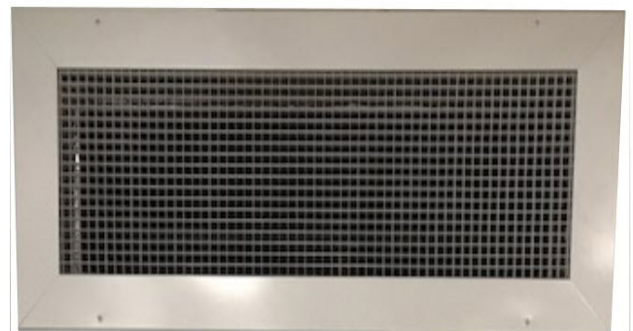

### 8620-286 Condenser Pre-Filter Kit for WR36 and WR58 Units

Bard offers a mesh filter that pre-filters the air entering the condenser coil. The mesh filter is washable and is meant to catch cottonwood seeds, leaves, and larger debris before it enters the condenser coil fin area. The filter must be cleaned on a regular basis to ensure condenser airflow is adequate for proper unit operation and optimal energy efficiency.



# FUSION-TEC™ Wall Curbs (Sold Separately)

Curb Model	Description	Shipping Weight
REWC5-*	Wall curb that moves the unit away from the wall for unit replacement where the older unit supply is very close to roof line that extends away from the building. Use with WR36 and WR58 unit.	57 pounds
REWC53-*	Wall curb that moves the unit away from the wall for unit replacement, and allows for the use of an existing 3 ton unit wall opening configuration. Use with WR36 and WR58 unit.	57 pounds

\* = x- Beige, 4- Buckeye Gray

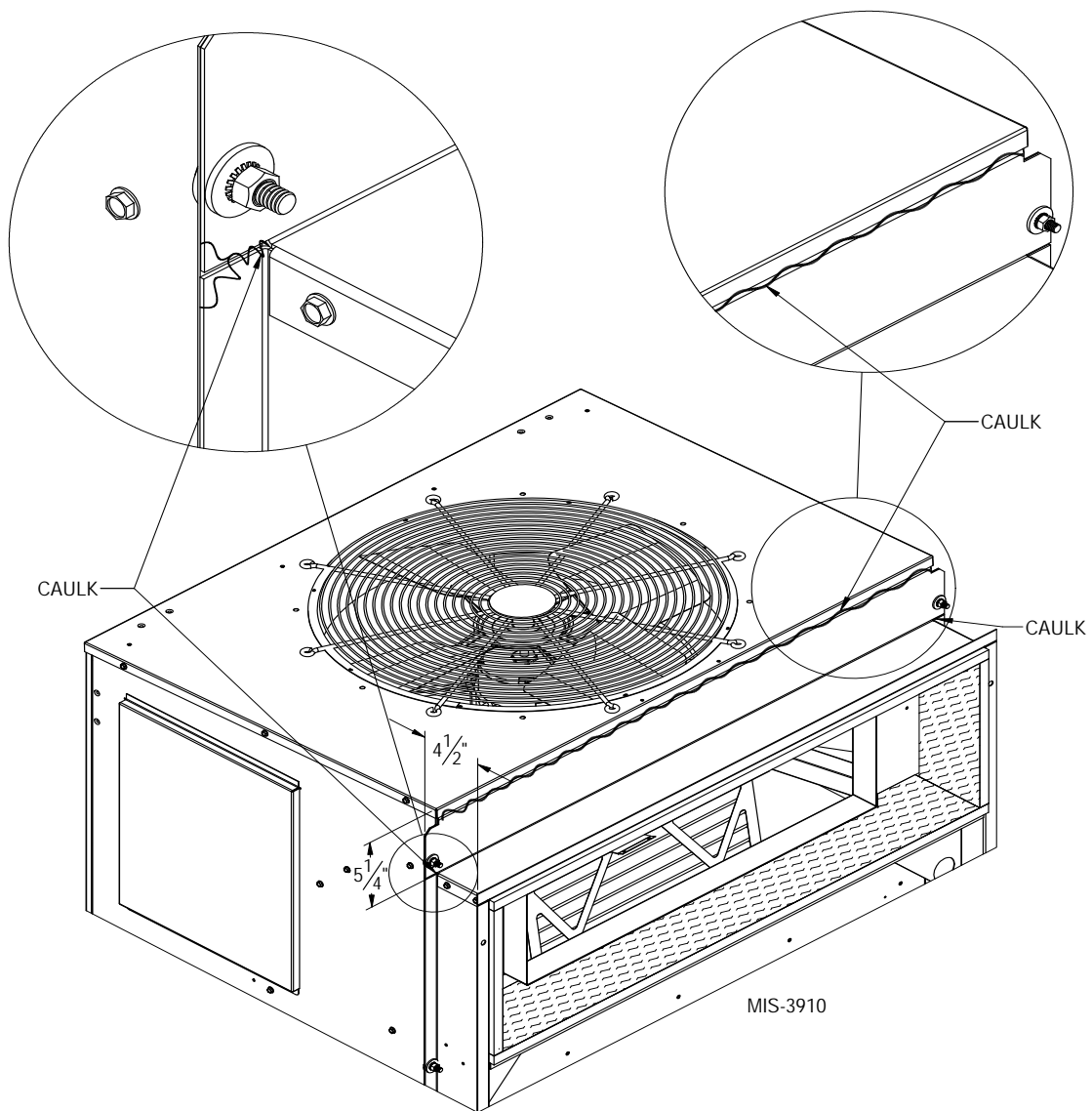

## WR Series Field-Supplied Installation Items, Wiring

Component	Reason for Use
<b>Wiring – All Units</b>	
18 Gauge 2 Wire Shielded Cable with drain	This is <b>required</b> to communicate between each FUSION-TEC™ unit and the LC6000 controller. When calculating wire length that is needed, be sure to include routing distance to each unit, conduit requirements and a loop for an EMI ferrite filter inside each unit control panel.
18 Gauge 5 Wire Shielded Cable with drain	This is <b>required</b> to communicate between the indoor remote temperature and humidity sensor and the LC6000 controller. When calculating wire length that is needed, be sure to include routing distance between the sensor location and controller, conduit requirements and routing inside the LC6000 panel to the terminal block. 18 gauge 6 wire shielded cable may be used if an extra conductor (wire) is desired.
Main Unit Power Wiring, 230VAC	This is <b>required</b> to supply power to the unit for compressor, ventilation and electric heat operation. When calculating wire length that is needed, be sure to include routing distance between the power source and the VAC circuit breaker inside the unit, and the conduit requirements. Be sure to follow all wire sizing and routing requirements supplied in this document and the installation manual.
LC6000 Controller Power Wiring,	This is <b>required</b> to supply power to the LC6000 controller. When calculating wire length that is needed, be sure to include routing distance between the power source and the VAC connection point inside the LC6000 controller, and the conduit requirements. Be sure to follow all wire sizing and routing requirements supplied in the LC6000 specification sheet and the LC6000 installation manual.
18 Gauge 2 Wire Shielded Cable	This is <b>optional</b> to communicate between an additional indoor temperature sensor and the LC6000 controller. When calculating wire length that is needed, be sure to include routing distance between the sensor location and controller, conduit requirements and routing inside the LC6000 panel to the terminal block.

## Field-Supplied Installation Items, Bard Guard™

Component	Reason for Use
<b>Wiring – All Units</b>	
18 Gauge 4 Wire Cable	This is <b>required</b> to communicate between FUSION-TEC™ unit 1, unit 2 and the BG1000 security interface. When calculating wire length that is needed, be sure to include routing distance to each unit and conduit requirements. 18 gauge 6 wire cable may be used if extra conductors are desired.
18 Gauge 2 Wire Cable	This is <b>required</b> to communicate between FUSION-TEC™ unit 3, unit 4 and the BG1000 security interface. When calculating wire length that is needed, be sure to include routing distance to each unit and conduit requirements. It is also <b>required</b> to communicate between the BG1000, the LC6000 and the 66 block NOC connection.
16 Gauge LC Controller Power Wiring, -48VDC	This is <b>required</b> to supply power to the BG1000 security interface. When calculating wire length that is needed, be sure to include routing distance between the power source and the VAC connection point inside the BG1000, and the conduit requirements. Be sure to follow all wire sizing and routing requirements supplied in the BG1000 specification sheet and the installation manual.

# WR Series Field-Supplied Installation Items, Unit

Component	Reason for Use
<b>Unit Installation</b>	
Wall Fasteners for Unit	Ten (10) cement fasteners, wall lag bolts or other fasteners are <b>required</b> to mount the FUSION-TEC™ product to the wall structure. Ø.375 holes are provided in the wall mounting flange on each side of the FUSION-TEC™ unit. Fasteners must be field specified based on the wall structure.
Wall Fasteners for Rain Flashing	Seven (7) cement or wood screws are <b>required</b> to mount the FUSION-TEC™ rain flashing to the wall structure. Ø.250 holes are provided in the top of the rain flashing. Fasteners must be field specified based on the wall structure.
Exterior Silicone Caulk	This is <b>required</b> to form a watertight seal between the FUSION-TEC™ unit and the wall. Choose an outdoor rated premium silicone caulk and follow all installation instructions provided with the FUSION-TEC™ unit.
230VAC Main Unit Power Conduit	This is <b>required</b> to supply power to the unit for compressor, ventilation and electric heat operation. Hole plugs are provided on each side of the unit for 230V main power.
Communication Wire Conduit	This is <b>required</b> to supply communication to the unit logic control board. One hole plug is provided on each side of the unit for the communication wire.

## 18 Gauge 2 Wire Shielded Cable with Drain

Where specified, this wire is 18/2 18 Gauge Copper Conductor Stranded Shielded and a PVC jacket. Red and black are the preferred wire colors.



## 18 Gauge 5 Wire Shielded Cable with Drain

Where specified, this wire is 18/5 18 Gauge Copper Conductor Stranded Shielded and a PVC jacket. 18/6 (6 wire) may be used in place of 18/5 (5 wire) if an extra conductor is desired.



# WR Series Units with Bard Guard™ Security System

## Bard Guard™ Security System

The Bard Guard™ Security System is comprised of the following parts:

- Sensors and a speaker mounted in each unit. This is ordered by specifying the factory installed “S” control option as the last digit in the unit model nomenclature.
- The BG1000 Security Interface may be used for 1 to 4 units. This is sold separately and is installed inside the structure. Wires connect the BG1000 to the LC6000 series controller.
- A heavy duty hinged security frame that attaches to the unit. The security frame has four (4) locking nuts that require a special key to remove. The frame secures the front panels while allowing service access by removing the four (4) locking nuts and swinging the frame out of the way on four (4) provided hinges. This is ordered by specifying the factory installed “S” control option as the last digit in the unit model nomenclature.

## Bard Guard™ Electrical Diagram

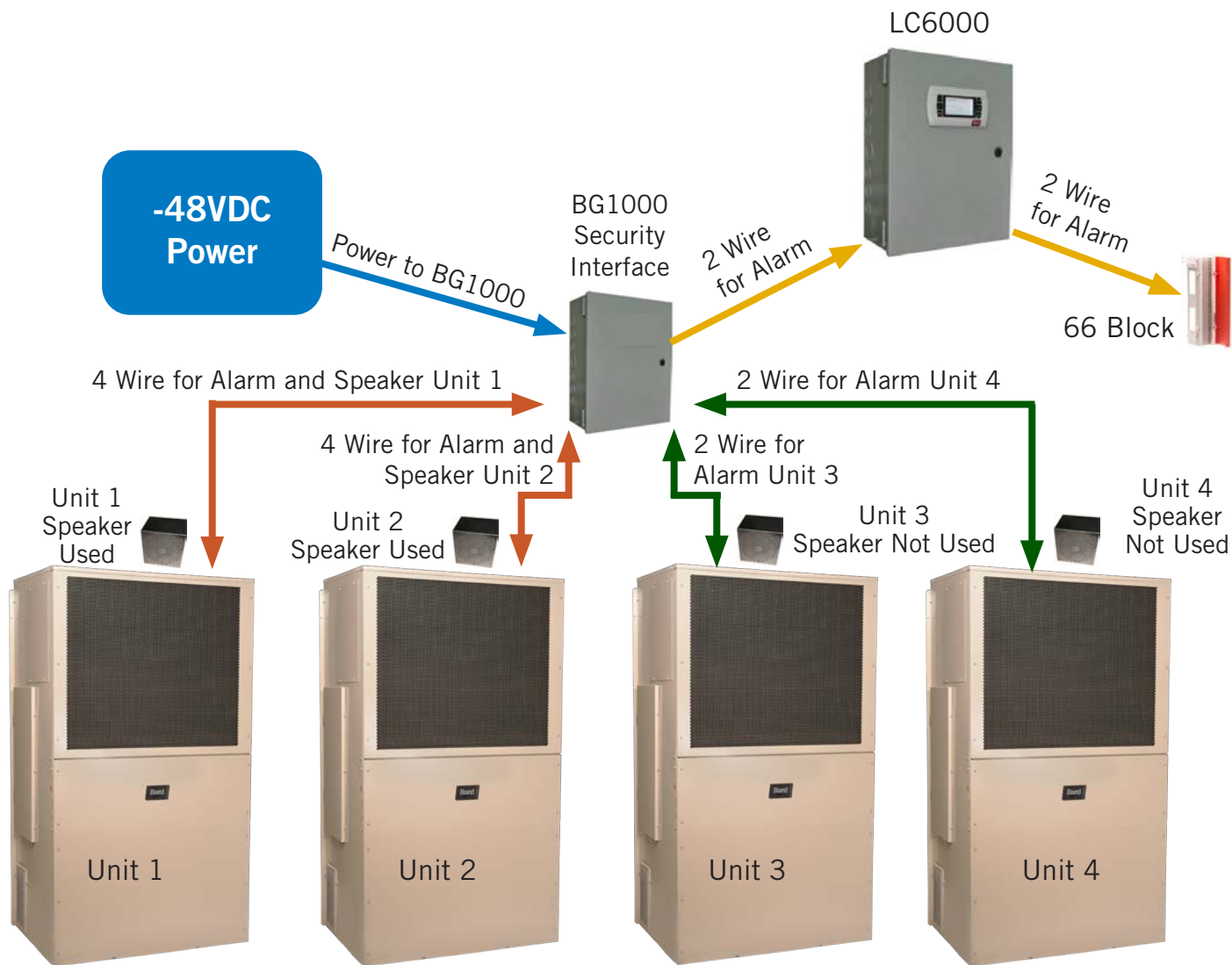



## WR Series Units with Bard Guard™ Security System

### **Bard Guard™ Unit "S" Controls Option** (Ordered with Unit)

The Bard Guard™ Security frame provides a way to lock the front doors, unit top and condenser coil to deter theft of internal unit components. The frame is comprised of heavy duty steel angle iron, welded and painted in a black finish. The frame is hinged at the top and has tamper resistant Tri-Socket fasteners at the bottom for easy service removal. A bottom tab is provided for a field supplied lock to be added for additional security. The Frame is shipped pre-installed on the FUSION-TEC unit when the "S" controls option is ordered. All required tamper resistant door switches and the internal 80db audio warning speaker are also provided with the unit when the "S" controls option is ordered. A loss of refrigerant pressure sends an alarm signal due to an additional system pressure monitoring switch. All components are pre-wired from the factory, and a simple four (4) wire connection is used to connect the FUSION-TEC™ unit security options to the BG1000 Security Interface (sold separately). Up to four (4) units can be used with a single BG1000 by running two (2) wires to each additional unit. Power is supplied by the BG1000 to operate up to two (2) unit audio warning speakers. The audio warning is given in both English and Spanish.



WR Series w/ Bard Guard™

### **Bard Guard™ Unit "S" Controls Option**

The Bard Guard "S" Controls option is used to order the FUSION-TEC™ unit with all required tamper resistant door switches and the internal 80db audio warning speaker. A loss of refrigerant pressure also sends an alarm signal. All components are pre-wired from the factory, and a simple four (4) wire connection is used to connect the FUSION-TEC™ unit security options to the BG1000 Security Interface. Up to four (4) units can be used with a single BG1000 by running two (2) wires to each additional unit. Power is supplied by the BG1000 to operate up to two (2) unit audio warning speakers. The audio warning is given in both English and Spanish.



BG1000  
Audio Warning Device

### **Bard Guard™ BG1000 Security Interface** (Sold Separately)

The Bard Guard security interface mounts to the wall inside the structure. -48VDC power is used to operate the security system. Two (2) indicator lights are provided to display "Armed" or "Disarmed". When armed, the system will apply power for up to 30 minutes to the unit speakers when unit system pressure is lost in any unit, or a door switch has been activated. An alarm signal will also be sent to the LC6000 controller. When disarmed, the system will remain inactive for up to 4 hours (user adjustable).



BG1000 Bard Guard™  
Interface



# Notes:



Bard Manufacturing Company, Inc.  
Bryan, Ohio 43506  
[www.bardhvac.com](http://www.bardhvac.com)

Due to our continuous product improvement policy,  
all specifications subject to change without notice.

Form No.  
S3564  
August 2020

Supersedes: 1019